

The logo for WCS Environmental Engineering features a teal wavy line above the text. The text 'WCS' is in a large, bold, dark blue font, followed by 'Environmental Engineering' in a smaller, dark blue font.

WCS Environmental
Engineering

A WCS Group Company

WCSEE LAMELLA SEPARATOR (LST)

**INSTALLATION & OPERATION AND
MAINTENANCE MANUAL**

TABLE OF CONTENTS

1. SAFETY	4
1.1. <i>Health and safety at work act 1974.....</i>	4
1.2. <i>General health and safety.....</i>	4
1.3. <i>Leptospirosis</i>	4
1.4. <i>Sensible Precautions</i>	5
1.5. <i>Vaccinations.....</i>	5
2. Warranty.....	5
2.1. <i>LAMELLA tank enclosures</i>	5
<i>WCSEE will provide a 12 month warranty period for the external & internal structure of the Lamella separator tank.</i>	5
2.2. <i>M&E installation</i>	6
2.3. <i>Warranty limitations and exemptions</i>	6
2.4. <i>Chargeable non warranty work</i>	6
3. Risk assessment	7
3.1. <i>Introduction</i>	7
3.1.1 <i>Installation Design Considerations</i>	7
3.1.2 <i>Installation and positioning</i>	8
3.1.3 <i>Maintenance.....</i>	8
4. Introduction	9
5. DELIVERY.....	10
5.1. <i>Off-Loading</i>	10
5.2. <i>Scope of Supply</i>	10
5.3. <i>Lifting</i>	10
6. TANK INSTALLATION FOR BELOW AND ABOVE GROUND LAMELLAS	12
6.1. <i>Introduction</i>	12
6.2. <i>Installation of below ground tank.....</i>	13
6.3. <i>Installation of above ground tank.....</i>	15
7. ROUTINE MAINTENANCE	16
7.1. <i>Applications:</i>	16
7.1.1. <i>Primary lamella separation:.....</i>	16
7.1.2. <i>Humus lamella separation:</i>	16
7.2. <i>Scum-Skimmer:</i>	16
7.3. <i>De-sludging:.....</i>	17
7.4. <i>Cleaning the PVC plates.....</i>	17
7.5. <i>Removing the PVC plates.....</i>	18
8. DECOMMISSIONING – ABOVE GROUND LAMELLA HIRE - UNIT	18

LIST OF FIGURES

Figure 5-1 WCSEE LAMELLA LIFTING PROCEDURE 11
 Figure 6-1 EXCAVATION 13
 Figure 6-2 BASE CASTING..... 13
 Figure 6-3 POSITIONING..... 14
 Figure 6-4 FILLING 15

LIST OF TABLES

Table 4.1 - TECHNICAL TABLE 9

Revision table:

Date	Change description	Owner	Checked	Rev
26/09/2017	First issue	TWC	TGH	A
08/11/2018	Note added ref – cleaning down of the Lamella	TWC	RT	B
22/01/2019	Revised Tank Construction	TWC	RT	C
13/11/2019	Revised Cleaning Regime	TWC	AB	D
22/01/2020	REVISED	TWC	AB	E
03/06/2020	REVISED	TWC	RT	F
12/06/2020	REVISED - MAINTENANCE	TWC	AB	G
18/08/2021	REVISED - BORDER	TWC	BD	H
12/10/2021	REVISED FOR CORRECTION	TWC	MR	I
09/06/2022	LST-20-AG INFO ADDED	TWC	BD	J
10/08/2022	DECOMMISSIONING REVISED	TWC	JC	K
25/08/2022	REVISED NOTES ON PAGE 16	TWC	AB	L
16/11/2022	REVISED FONT - WCSEE	TWC	BD	M
10/05/2024	Technical Table Revised	TWC	RT	N

WCSEE LAMELLA SEPARATOR TANKS

1. SAFETY

It is extremely important that maintenance procedures in this document are followed. Any deviation from this could cause serious injury or have a detrimental effect on its operation.

1.1. Health and safety at work act 1974

Section 6a of the act requires manufacturers to advise their customers on safety and handling precautions to be observed when operating, maintaining and servicing their products.

The user's attention should be drawn to the following:

- All sections of this manual should be read before undertaking work on the equipment.
- Suitably trained personnel must carry out the installation.
- Normal Health and safety precautions must be taken and appropriate procedures observed to avoid accidents.
- Refer to WCSEE for further technical advice or product information.

1.2. General health and safety

The layout of the WCSEE LST tanks have been laid out to ensure that health and safety on site is optimised in line with designer duties specified by the CDM regulations 2015. It will be safe manner, and agrees with comments from the principal designer. Lone working in, and around the plant should be prohibited.

1.3. Leptospirosis

The following is extracted from a health warning card issued to WCSEE staff. It is the client's responsibility to ensure that the relevant Personal Protective Equipment (PPE) is available and used.

There are two types of Leptospirosis that effect people in the UK and they are as follows:

- Weil's disease, which is a serious infection transmitted to humans by contact with soil, water or sewage that has become contaminated with urine from infected rats.
- Hardjo-type Leptospirosis, which is transmitted from cattle to humans.

The typical symptoms for both diseases start with a flu like illness, with a persistent and severe headache, muscle pains and vomiting. Jaundice generally appears on the fourth day of the illness.

The bacteria can enter your body through cuts and scratches or through the lining of the mouth, throat and eyes.

1.4. **Sensible Precautions**

After working with contaminated fluid or other materials it is important that hands and forearms are washed thoroughly with soap and water. If your clothing or boots become contaminated, then they should also be washed immediately after use.

Immediate action should be taken, so that any cuts scratches or abrasions are washed thoroughly with clean water, prior to applying any protective covering (plaster or bandage).

Do not handle food, drink or smoking material without first washing your hands. If you display any of the symptoms described after coming in to contact with sewage; report to your doctor immediately advising them of the circumstances.

1.5. **Vaccinations**

To avoid the possibility of illness it is recommended that all site personnel have the following vaccinations. WCSEE also recommends that you that you consult your doctor for any additional vaccinations that you may require. The general vaccinations WCSEE use for all personnel are as follows:

- Hepatitis A
- Hepatitis B
- Polio
- Tetanus
- Typhoid/cholera – probably carried out as a child.

2. **Warranty**

WCSEE will provide the following warranty to the items listed below:

Note: warranty period will be active from the day, from which the tanks are positioned on the base slab, or passes on to the customer's premises/construction site.

2.1. **LAMELLA tank enclosures**

WCSEE will provide a 12 month warranty period for the external & internal structure of the Lamella separator tank.

2.2. **M&E installation**

WCSEE takes no responsibility for improper storage, or bad installation/maintenance performed by unqualified personnel. This also covers the overloading of the plates, above that of normal conditions, and any other accidental cause, or disregard for the information in this document.

2.3. **Warranty limitations and exemptions**

WCSEE shall not be liable for any labor involved for the removal or replacement of its equipment or the subsequent transportation, handling or packaging of any part or parts thereof. In no case will WCSEE be liable for loss incurred because of interruption of service or for consequential damages, labor or expense required to repair defective units, nor shall this constitute a cause for the cancellation of the contract of purchase and sale. Specifically exempt from this warranty are limited life of consumable components subject to normal wear and tear.

2.4. **Chargeable non warranty work**

Service charges will be incurred (including parts and labour), due to the following:

- Unauthorized alteration.
- Accidental damage, caused by plant or movement on site outside of WCSEE's control.
- Improper use.
- Abuse.
- Tampering.
- Failure to follow installation instructions or failure to follow operating and maintenance procedures.

The above will not be covered by this warranty. All service visits for non-warranty work are chargeable at the standard engineer day rate plus mobilization. This warranty gives specific additional benefits. Statutory rights are unaffected.

Note: WCSEE will not uphold the guarantee on the purchased equipment if the routine maintenance has not been performed and documented.

WCSEE strongly recommends that the installation of the purchased product is carried out by a qualified and experienced installer. Dependent on the site a suitably qualified civil engineer may need to be consulted for the construction of suitable base slab to support the imposed load.

3. Risk assessment

3.1. Introduction

This section of the manual is intended as a guide and as such does not cater for every situation encountered on site. WCSEE assumes that the necessary permissions have been granted prior to the installation of the plant. It is also the assumption that working methodology abides by the Health and Safety at work act and that all civil engineering design is undertaken by a chartered Civil Engineer.

Please ensure that due consideration is given to the following:

3.1.1 Installation Design Considerations

- Planning permissions & Building Regulations and other regulating or interested parties.
- Environment Agency consent to discharge.
- The size of the plant relevant to the number and type of people that will be using it, e.g. domestic, light industrial, etc.
- Costs, legal implications and siting in consideration to shared systems.
- The whereabouts of wells, boreholes and springs used as sources of potable water; existing non-mains sewerage systems and soakaways; water courses, ponds and lakes and designated protected areas.
- The whereabouts of other services, pipes, cables and ducting.
- Local ground conditions. Is specialist knowledge of civil engineering required, catering for specific ground condition requirements?
- The water table at the time of installation - specialist knowledge is required when installing in an excavation that allows water to enter.
- The water table in winter - Special consideration should be given to installations that will be subject to high water table pressure or flood conditions. The treatment plant will need to be installed so that it cannot "float" out of the ground and provision made for continued discharge of treated effluent, should the discharge pipework/soakaway be under water.
- The below ground Lamella has been designed to key into the surrounding concrete.

3.1.2 Installation and positioning

- **Siting** - The plant must be sited within 30m of heavy vehicle access for de-sludging. The plant should be sited as far from the habitable parts of the dwelling as possible. Many local authorities recommend 10m as a minimum, but easements are possible for smaller sites.
- **Electrical supply** – If the plant has been equipped with a pumped de-sludge option, a qualified electrician should only undertake electrical installation. A safe and reliable power supply is required at all times, as the pumps are required to de-sludge at intervals 24/7. Adequate means of power failure indication should be provided. This can be an audible or visual alarm or by regular manual checks.

Note: Due to the health risks associated with raw sewage, WCSEE recommend that the LST treatment plant is not used until the system is complete, commissioned and is operating in a stable manner.

3.1.3 Maintenance

- The legal responsibility for the plant as far as operation and maintenance and on-going discharge is concerned is the end user.
- Electrical supply: a qualified electrician should undertake the electrical installation.
A reliable power supply will be required at all times, so an indication of power failure will be required, which can be audible or visual.
- Before carrying out any maintenance or installation on the equipment it should be electrically isolated, unless a trained electrician is carrying out specific checks under controlled conditions. When performing works of this nature, warning signs should be erected to alert others of the works in progress.
- For all works, risk assessments and method statements will be required to carry out work on site. These should identify the method of work and the risks associated.
- Temporary barriers and warning signs should be erected around any open covers or manholes as appropriate, in particular warning of deep water in the tanks.
- See section 7 for routine maintenance.

Notes:-

- The tank has a 1 year manufacturing defects guarantee
- A visual inspection should be regularly undertaken, signs of rust, chips or damaged paint should be cleaned and re-painted
- A full structural inspection should be undertaken every 10 years
- Any galvanised components showing visual signs of corrosion should be treated or replaced.

4. Introduction

The WCSEE Lamella range is to meet your liquid/solids separation requirements. The following product codes shown below are used for the standard WCSEE product range:

SPECIFICATION	LAMELLA RANGE		
	LST-20-AG	LST-50-BG	LST-50-AG
MAX FLOW RATE	20m ³ /h	50 m ³ /h	50 m ³ /h
LENGTH (mm)	2454mm	3786mm	3786mm
WIDTH (mm)	1715mm	1715mm	1715mm
HEIGHT (mm)	2500mm	2500mm	2500mm
DRY WEIGHT	1,500 KG	3,000 KG	3,000 KG
OPERATING WEIGHT	4,500KG	10,000 KG	10,000 KG
INLET	DN100 PN16 FLANGE	DN200 PN16 FLANGE	DN200 PN16 FLANGE
OUTLET	DN100 PN16 FLANGE	DN200 PN16 FLANGE	DN200 PN16 FLANGE
SLUDGE OUTLET	DN100 PN16 FLANGE	DN100 PN16 FLANGE	DN100 PN16 FLANGE
LAMELLA PLATE AREA	23.15m ²	57.33m ²	57.33m ²
PLATE ANGLE	60 Deg	60 Deg	60 Deg
PLATE SPACING	40.3mm	40.3mm	40.3mm
PLATE WEIGHT	4KG	4KG	4KG
HYDRAULIC LOADING m/h	1.16	1.15	1.15
AIR SPARGE FITTING	PCL SC21JM	-	PCL SC21JM
SOLIDS REMOVAL	95% PARTICLES	95% PARTICLES	95% PARTICLES
TOTAL VOL OF UNIT	3.07m ³	6.15m ³	6.15m ³
VOL OF SLUDGE HOPPERS	0.64m ³	1.28m ³	1.28m ³
FOOT PRINT (m)	1.75 x 1.46	3.52m x 1.61m	3.78m x 1.46m

Table 4.1 - TECHNICAL TABLE

“AB” = ABOVE GROUND, “BG” = BELOW GROUND

5. DELIVERY

5.1. Off-Loading

The customer may be responsible for off-loading. If so the plant should be offloaded to the nearest roadway, which has been swept, is free from stones or rocks and is suitable for heavy goods vehicles. A minimum height clearance of 5m is required. If overhead cables are present, the electrical supply should be isolated before the lift. When off-loading using a lorry mounted HIAB, suitable ground conditions will be required for the stabilisers, and a minimum width of 5m.

If the nearest road access for a heavy goods vehicle is not adjacent to the site, it is the responsibility of the customer to arrange transport from the road to the site. If site access does not allow for heavy goods vehicles then

 Inspect the unit for any damage to the base removing the unit from the delivery vehicle. Any damage following the off-loading of the treatment plant will be deemed the responsibility of the plant owner.

5.2. Scope of Supply

See the delivery note for full details. The standard unit comes with the following:

- The WCSEE LST 50 LAMELLA for above or below ground installation.
- Other specific equipment will be listed in the PO and the delivery note.
- If the tank is part of a package, and includes a de-sludge pump, control panel and pipework, see the control philosophy and project design drawings for details.
- Moving/transporting the unit must be empty of fluids.

5.3. Lifting

Loading and unloading should only be performed by suitably trained persons, who can provide the correct certifications for the lift and test certificates for lifting equipment, in accordance with the LOLER regulations. This also includes the removal and stowing of strops and other load fixings. Health and safety regulations must be followed implicitly. WCSEE are able to provide, on request, test certificates in accordance with LOLER regulations.

WCSEE advises the following for lifting practices for the Lamella tanks:

Checks:

- Inspect all lifting shackles and tension if required with a suitable tool.
- The unit must be hoisted empty of any fluids.
- Test lift the unit to check that the centre of gravity of the unit hanging central. (See drawing supplied by WCSEE and that all of the chains are taut. It is critical to ensure a balanced lift, but if in doubt don't lift the tank.

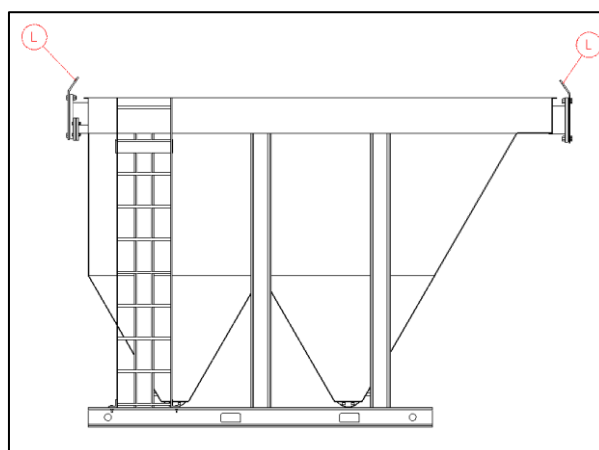

Figure 5-1 WCSE LAMELLA LIFTING PROCEDURE

- Lifting holes are provided for on the top edge of the lifting bracket which is bolted onto the Lamella Unit. for the attachment of suitable strops for the weights listed in Table 4.1.
- The strop/chain angle should be no less than 60° from the top of the unit to avoid excessive load on the tanks structure.
- Care should be taken to avoid detachment of the load when transporting the Lamella on uneven ground. The securing of the plant and associated equipment will be at the discretion of the delivery company and any damage caused thereof will not be the responsibility of WCSEE.
- Care should be taken when attaching lifting equipment. WCSEE strongly discourages walking over the top of the Lamella tank whilst on the back of a delivery vehicle unless a fall arrest system/harness is in place.

6. TANK INSTALLATION FOR BELOW AND ABOVE GROUND LAMELLAS

6.1. Introduction

All installation procedures should be carried out observing the requirements of the Health and Safety at Work Act 1974 and involve a safe system of work for all activities, whilst applying the general principles of prevention. Only suitably qualified persons should perform any construction work relating to, installation, commissioning and maintenance of WCSEE plant. Any damage caused, which is not a manufacturing defect will be chargeable.

The top of the Lamella may be fitted with GRP Gridding to act a working platform for below units only.

WCSEE recommends consulting a chartered civil engineer to advise on the ground conditions and whether there are likely to be any specific requirements for the installation.

Calculate the type and amount of backfill required for the installation of the plant, following consultation with a chartered civil engineer. Prevailing ground conditions may dictate the type of installation and installation method. A wet mix of concrete should be used for the base slab shown in Figure 6-1 and Figure 6-2 and also for the mass surround to anchor the structure of the Lamella in position.

During the course of installation, the following will be required:

- Normal construction equipment and plant. Specific equipment may be required dependent on the ground conditions and size of the plant.
- Concrete for the base and sides of the plant. The base slab should be suitably designed, such that it supports the below ground Lamella when in operation, to the load shown
- An adequate supply of water to fill unit, during the concrete pour.
- Pumping equipment where necessary.

In cases where the ground water table is high and water can present a load on the surface of the tank, specialist advice should be sought to avoid crushing the tank. WCSEE should always be aware of the groundwater level before an order is placed.

Venting - All sewage treatment processes produce waste gasses, which can give rise to unpleasant odours; therefore, it is recommended for primary Lamella's that the plant be vented using a standard vent stack.

When installing the below ground Lamella, the de-sludge pipework should be assembled prior to casting it in concrete.

6.2. Installation of below ground tank

Please note that the procedure below does not override any governing health and safety requirements specific to the site specific environmental conditions.

Step 1: Stabilise unit in excavation, making sure that the excavation sides are not likely to move or collapse and that the concrete can be poured with ease. Fit temporary bungs in all pipe connections to prevent the escape of water into the excavation during the last concrete pour.

Step 2: Excavate to tank dimensions (See 4.1) with minimum of 500mm clearance all round and minimum of 500mm under the base of the unit. Allow adequate clearance for all pipes and hose connections to the unit, particularly when installing de-sludge connections.

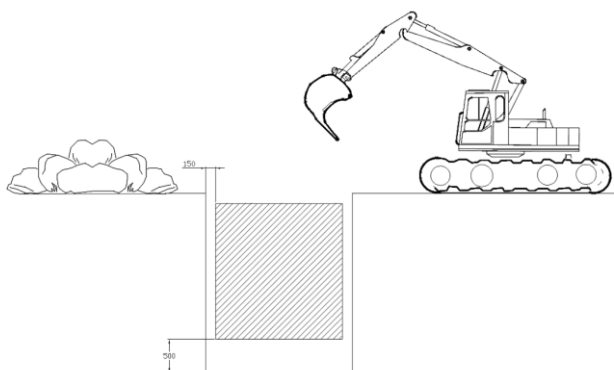

Figure 6-1 EXCAVATION

Step 3: Cast the concrete base slab ensuring that it has been designed to support the unit in normal operation (i.e. full of water). The base must be constructed to $\pm 5\text{mm}$ from its datum point (invert level of Lamella inlet). Any variance in level should be rectified using a self-levelling grout, ensuring an even bearing to the base slab.

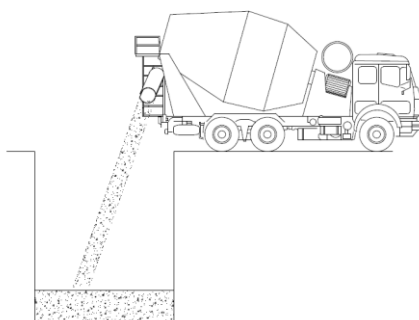

Figure 6-2 BASE CASTING

Step 4: Excavation must be kept dry during the installation and until the concrete has cured. Therefore, a cover or tarpaulin may be required to prevent rainfall coming into contact with the wet concrete.

Step 5: Ensure the surface of the concrete base is free of water; stones and other debris. This is typically done using a stiff brush or squeegee. The tolerance for the slab should be $\pm 5\text{mm}$, allowing a maximum possible variance of 10mm (5mm in either direction).

Step 6: Mark up the base slab with the desired position of the tank and lower the unit into correct position which corresponds with the pipe connections to and from the tank. Please ensure at this stage that the inlet and outlet connections correspond with the approved drawings.

Step 7: Check the levels and that all of the connections to the tank can be made with ease.

Step 8: Provide packing to ensure that the LST-50 unit is level in all directions, providing grout as a finish.

Step 9: Once levelled and positioned, secure the Lamella to the concrete base slab with M16, anchor bolts on each Lamella foot, (four on each Lamella foot).

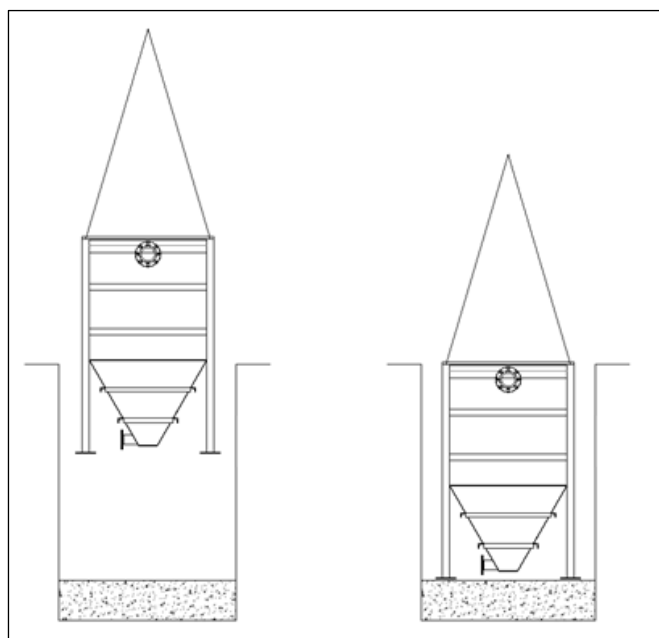

Figure 6-3 POSITIONING

Step 10: Fill the tank such that all sections have a level of 1500mm. Please ensure that all sections are checked prior to the commencement of the backfilling process, and if any areas are deficient of fluid then they must be topped up. It is critical that this level is maintained at 1500mm above the concrete during the entire pour.

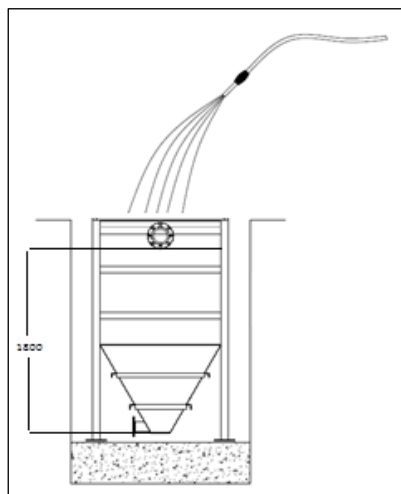

Figure 6-4 FILLING

Step 11: Commence back filling with wet mix (actual mix ratio to be determined by a qualified civil engineer).

6.3. Installation of above ground tank

Step 1: The unit should be set on a structurally sound base capable of withstanding the full tank weight of the LST-50 Table 4.1. The slab must be level for the best performance (± 5 mm in all directions).

Step 2: Concrete base must be fully cured before the Lamella is positioned. Therefore, a cover or tarpaulin may be required to prevent rainfall coming into contact with the wet concrete.

Step 3: Mark up the base slab with the desired position of the tank and lower the unit into correct position which corresponds with the pipe connections to and from the tank. Please ensure at this stage that the inlet and outlet connections correspond with the approved drawings.

Step 4: Once positioned and finalised, secure the Lamella to the base slab with M16, anchor bolts on each Lamella foot, (four on each Lamella foot).

7. ROUTINE MAINTENANCE

Removal of plates is required to clean the Lamella plate's properly. A safe system of work should be put in place prior to carrying out the maintenance and cleaning. It is recommended that the operator undertaking the work shall be equipped with a fall arrest system from a suitable rated fixed point.

Note:- The lamella plate separator 'V' notch weirs are designed to even flow across the lamella in low flow situations, negating the requirement to have adjustable weirs fitted. It is normal to have the top of the weir plate 'V's fully submerged during full flow conditions.

7.1. Applications:

Typically there will be two common applications for lamella separators in domestic and municipal wastewater applications. Each of the applications is covered in the following sections:

7.1.1. Primary lamella separation:

It is recommended that in primary lamella applications, pre-screening is provided, with the use of a 6mm bar screen. This will prevent bulk solids and rags blinding the plate pack and leading to the carryover of solids in to secondary processes. The accumulated sludge's in a primary settlement applications will be dependent on the specific influent conditions and therefore de-sludging should be optimised by the end user.

7.1.2. Humus lamella separation:

In humus applications, sludge's should be removed little and often from the vessel.

7.2. Scum-Skimmer:

If the Lamella you have has been installed with a manually adjustable Weir Scum Skimmer, It is designed to capture the floating scum where it will weir over through to a 2", DN50 flanged outlet.

The Weir is to be positioned 20mm below the operating fluid level within the Lamella. This is to be set on commissioning, dependant on the flow rate coming in as the flow rate will determine the height of the weir plate.

The scum outlet is equipped with a 2" ball valve. This is positioned before the DN50 flange outlet to enable a safe isolation for the operator.

When the Lamella is in operation it should be known that before de-sludging the twin hoppers, the Weir Scum Skimmer should be operated first, to enable the fluid to weir over.

If the twin hoppers are de-sludged before the Weir Scum Skimmer, the fluid level will be too low, and will not weir over.

No maintenance is required, however quarterly checks is recommended.

7.3. De-sludging:

In the event that a lamella becomes blinded with accumulated sludge's, it is recommended that the lamella be de-sludged in the following sequence:

Following desludging the operator should watch the discharge to visually ascertain the length of time to clear the deposited solids, i.e. until the flow quickens or becomes clear. The sludge shall also be drained via pump through these connections prior moving the Unit. These connections are 2 off, DN100/4". Below ground Lamella's may have a reducer flange (depending on the de-sludge pump size and the suction lift). De-sludging the Lamella should be timed on the below parameters (should only be used as a guide):-

For Pumped Applications	For Gravity Applications
4 mins ON	5 secs OPEN
45 mins OFF	45 mins CLOSED

For Above Ground installations on LST-50 range only: - During maintenance, if the weir channels become clogged or there is a lot of grit accumulating, there is a 2" DN50 blanked off flange situated at the end of each of the two channels. This can be removed and used to flush any sediment out.

An air sparge is fitted to the bottom of each hopper. This is a PCL SC21JM. This is used to break up the solids which have accumulated and gone hard. Blasting the hopper with air will break up the solids, and ease solids removal.

7.4. Cleaning the PVC plates

Cleaning of the plates should only be carried out when the Lamella is empty of all fluid.

The plates should be cleaned on a regular basis, provided the sludge hasn't been left to build up for too long. The surface of the PVC plates are smooth and cleaning of the plates should be carried out by a competent service engineer using appropriate PPE with a pressure washer on site. The exact frequency of cleaning can be determined by the operator that should check on a weekly basis.

To aid the surface of the plates from clogging up, avoid emptying the tank and leaving the tank to dry (without cleaning the plates) as this will encourage a build-up of solids.

7.5. Removing the PVC plates

The plates can be removed but should be avoided as it will contain hazardous substances. The plates weigh approximately 10kg each with sludge attached. The plates can get clogged and to avoid this, plate cleaning should be carried out regularly.

8. DECOMMISSIONING – ABOVE GROUND LAMELLA HIRE - UNIT

Decommissioning the Lamella, the customer is responsible for cleaning and making sure the unit is in a satisfactory state, as it was delivered to site.

When carrying out any of the decommissioning checks below, it is expected that for a safe method of cleaning, access platforms should be used with fresh, warm water with bleach.

These checks will include of the following:-

- Emptying the Lamella fully – making sure no residue remains in the vessel.
- Pressure wash each PVC plate (both sides) making sure that all sludge is removed.
- Cleaning all inlet/outlet flanges from any sludge build up (with a stiff brush and clean water).
- Pressure wash the external frame with an anti-bacterial detergent.
- If supplied with any supply loose items, these are to be cleaned and packaged back onto a pallet tightly, ready for delivery.
- Any material, which have been in contact with the process fluid, which have not been disinfected should be disposed of using the correct means.

It is advised to take pictures with dates upon receiving the Lamella Hire unit and any kit of parts, as this can be cross-checked when decommissioning.

If none of the above has been carried out or parts are damaged or missing from the kit of what was supplied, the customer will be liable for any costs incurred to have the unit back in an appropriate state. WCSEE fully understands sites and restrictions, so if any notice can be given prior to any of the above not being carried out, we would appreciate a pre warning phone call on 02392242600, and will be able to help or advise.

 **Inspect the unit for any damages to the tank once the unit is ready for decommissioning and delivery. Any damage following the hire of the unit or on/off-loading of the treatment plant will be deemed the responsibility of the plant owner.**

Industrial wastewater treatment

+44 (0) 15 3083 0020

Sewage treatment

+44 (0) 23 9224 2600

info@wcs-group.co.uk

wcs-group.co.uk/environmental-engineering

Disclaimer

WCS Environmental Engineering (WCSEE) has a policy of continual product development and the above information may be subject to change without notice. WCSEE reserve the right to to change the specification in line with company policy of improvement through research and development. Errors and omissions excepted. Models shown in this manual may include additional cost options that are not part of the standard specification