

The logo for WCS Environmental Engineering features a teal swoosh above the text. The text 'WCS' is in a large, bold, dark blue font, followed by 'Environmental Engineering' in a smaller, dark blue font.

WCS Environmental
Engineering

A WCS Group Company

HPC

OPERATION & MAINTENANCE MANUAL

SITE NAME:

REFERENCE NUMBER:

TABLE OF CONTENTS

1	HEALTH AND SAFETY	4
1.1	United Kingdom Health and Safety at Work Act 1974	4
1.2	Who is at risk?	4
1.3	What are the health risks?	4
1.4	Sensible Precautions	5
1.5	Safety.....	5
1.6	Vaccinations.....	5
1.7	<i>Work at Heights</i>	5
1.8	Confined Spaces	6
2	RISK ASSESSMENT NOTES	6
3	INTRODUCTION OF THE PLANT	8
4	PLANT OPERATION.....	9
4.1	Primary Settlement Tank Operation.....	9
4.1.1	Operation.....	9
4.1.2	Emptying.....	9
4.2	Bio-zone Operation	9
4.2.1	Maintenance of the Bio-zone Tank	10
4.3	Fan Operation and Control.....	10
4.4	Blower Operation and Control.....	10
4.4.1	Automatic Control	10
4.4.2	TIMER.....	11
4.4.3	Manual Control.....	13
5	ROUTINE MAINTENANCE.....	14
5.1	Weekly	14
5.2	Six Monthly.....	14
5.3	Annual.....	15
6	PROBLEM SOLVING.....	16
6.1	Poor Effluent.....	16
6.2	Blower not running.....	16

6.3 No air bubbles showing on the surface of the filter section..... 16

6.4 Blockages..... 17

6.5 Smell..... 17

6.6 Poor Air Distribution over the Filter Section..... 18

6.7 Floating scum layer on final settlement tank 19

7 AIR BLOWERS..... 19

8 WARRANTY LIMITATIONS 20

9 NON-WARRANTY SERVICES..... 20

Revision History:

Date	Change description	Owner	Checked	Revision
03/11/2022	2022 ISSUE	BD	TC	A
26/02/2024	2024 – Company Info updated	BD	TC	B

1 HEALTH AND SAFETY

1.1 United Kingdom Health and Safety at Work Act 1974

The Health and Safety at Work Act 1974 (also referred to as HSWA, the HSW Act, the 1974 Act or HASAWA) is the primary piece of legislation covering occupational health and safety in Great Britain. The Health and Safety Executive, with local authorities (and other enforcing authorities) is responsible for enforcing the Act and a number of other Acts and Statutory Instruments relevant to the working environment, legal and other binding regulations for accident prevention have to be observed and instructed in addition to the operating manual.

Several work activities bring workers into contact with sewage and sewage products. Each year, some workers will suffer from at least one episode of work-related illness. The majority of illnesses are relatively mild cases of gastroenteritis, but potentially fatal diseases, such as leptospirosis (Weil's disease) and hepatitis, are also reported.

1.2 Who is at risk?

If you work in one of the following areas, your health, or that of your employees, may be at risk:

- Local authority employees involved in sewer inspection and maintenance work.
- Construction workers who repair or replace live sewers.
- Water company employees who work with sewage treatment plant.
- Agricultural and forestry workers who may be exposed to sewage sludge.
- Sludge tanker drivers/operators and associated maintenance staff.
- Plumbers or employees who clean and maintain the underside of railway carriages and empty aircraft sewage compartments and other types of portable lavatories.

1.3 What are the health risks?

Exposure to sewage or its products may result in a number of illnesses. These include:

- Gastroenteritis, characterised by cramping stomach pains, diarrhoea and vomiting.
- Weil's disease, a flu-like illness with persistent and severe headache, transmitted by rat urine. Damage to liver, kidneys and blood may occur and the condition can be fatal.
- Hepatitis, characterised by inflammation of the liver, and jaundice.
- Occupational asthma, resulting in attacks of breathlessness, chest tightness and wheezing, and produced by the inhalation of living or dead organisms.
- Infection of skin or eyes; and/or rarely, allergic alveolitis (inflammation of the lung) with fever, breathlessness, dry cough, and aching muscles and joints.

1.4 Sensible Precautions

- After having worked in sewage or with anything contaminated with sewage, wash your hands and forearms thoroughly with soap and water. If your clothing or boots are contaminated with sewage, wash thoroughly after handling them.
- Take immediate action to wash thoroughly, with clean water, any cut, scratch or abrasion of the skin prior to applying a protective covering.
- Do not handle food, drink or smoking material without first washing your hands. If you contract the symptoms described after coming into contact with sewage, report to your doctor immediately and advise him/her of the circumstances.

1.5 Safety

- Sewage gases are potentially explosive and toxic, therefore any attempts to gain access to the interior of the tank must be carried out by suitably trained and qualified personnel and after strictly meeting all health and safety requirements.
- Before carrying out any maintenance work, the equipment must be electrically isolated.
- Do not leave covers open for longer than necessary. Temporary barriers and warning signs should be erected around any open covers or manholes as appropriate, in particular warning of deep water in the tanks.
- Any visiting personnel must report to site office on arrival and fully acquaint themselves with safety regulations applicable.
- Normal safety precautions must be taken and appropriate procedures observed to avoid accidents.

1.6 Vaccinations

To avoid illness, it is recommended that site personnel have the following vaccinations. (Your doctor may recommend further).

- Hepatitis A
- Hepatitis B
- Polio
- Tetanus
- Typhoid/Cholera (probably carried out as a child).

1.7 Work at Heights

Employers and those in control of any work at height activity must make sure work is properly planned, supervised and carried out by competent people. This includes using the right type of equipment for working at height. Low-risk, relatively straightforward tasks will require less effort when it comes to planning. Refer to The Work at Height Regulations 2005 for more details.

1.8 Confined Spaces

A confined space is a place which is substantially enclosed (though not always entirely), and where serious injury can occur from hazardous substances or conditions within the space or nearby (e.g. lack of oxygen).

Under domestic law (the Health and Safety at Work Act 1974) employers are responsible for ensuring the safety of their employees and others. This responsibility is reinforced by regulations.

2 RISK ASSESSMENT NOTES

This section of the manual is intended as a guide and as such does not cater for every situation that may be experienced on site. WCSEE Ltd assumes that the installer/end user has ensured that all necessary permissions have been sought and granted and that the installation procedures will be carried out observing the requirements of the Health & Safety regulations and will involve good building and sound civil engineering practice. Please ensure that due consideration has been given to and appropriate action taken with regard to the following:

- Planning permissions & Building Regulations and other regulating or interested parties.
- Environment Agency consent to discharge.
- The legal responsibility for the plant as far as operation and maintenance and ongoing discharge is concerned.
- Failure to comply with any regulation may result in pollution, odour and nuisance and health hazards, which may lead to legal action.
- The size of the plant relevant to the number and type of people that will be using it, e.g. domestic, light industrial, etc. consideration should be given to any unusual conditions such as B & B accommodation, special laundry requirements and frequent entertaining.
- Costs, legal implications and siting in consideration to shared systems.
- The whereabouts of wells, boreholes and springs used as sources of potable water; existing non-mains sewerage systems and soakaways; water courses, ponds and lakes and designated protected areas.
- The whereabouts of other services, pipes, cables, ducts, etc.
- Local ground conditions. Is specialist knowledge of civil engineering required to cater for unusual soil conditions such as underground rivers, running sand, chemicals in the soil, etc?
- The water table at the time of installation. Specialist knowledge is required when installing in an excavation that allows water to enter.
- The water table in winter. Special consideration should be given to installations that will be subject to high water table pressure or flood conditions. The treatment plant will need to be installed so that it cannot "float" out of the ground and provision made for continued discharge of treated effluent, should the discharge pipework/soakaway be under water.

- Failure to maintain the ability to discharge may result in pollution, odour and nuisance and health hazards, which may lead to legal action. WCSEE Ltd cannot be held responsible for failure to discharge due to poorly designed, constructed or positioned soakaways and discharge pipework systems.
- The plant must be sited within 30m of heavy vehicle access for de-sludging. The plant should, where possible, be sited above the high water table mark and above or beyond the flood plain.
- The plant should be sited as far from the habitable parts of the dwelling as possible. Many local authorities recommend 10m as a minimum, but easements are possible for smaller sites.
- WCSEE Ltd recommend that the plant be vented. This can be via the vent pipe, normally attached to the building, or by additional venting (high or low level) off of the inlet or outlet pipework or the sample chamber.
- A safe and adequate sampling point is usually a requirement of the Environment Agency. This can be an off the shelf item or constructed using standard drainage components. Open pipe discharges to ditches, watercourses, etc, through pipework of less than 5m in length, do not require a sampling point if the effluent can be sampled from the end of the pipe.
- A qualified electrician (see Electrical Installation section) should only undertake electrical installation. A safe and reliable power supply is required at all times, as the air blower is required to run continuously. Adequate means of air or power failure indication should be provided. This can be an audible or visual alarm or by regular manual checks.
- Due to the health risks associated with raw sewage, WCSEE Ltd recommend that the sewage treatment plant is not used until the system is complete, commissioned and handed over.
- Before carrying out any maintenance or installation work, the equipment must be electrically isolated. Do not leave covers open for any longer than necessary. Temporary barriers and warning signs should be erected around any open covers or manholes as appropriate, in particular warning of deep water in the tanks.
- Any visiting personnel must report to site office or householder on arrival and fully acquaint themselves with safety regulations applicable.

3 INTRODUCTION OF THE PLANT

The HIPAF COMPACT “HPC” range of high-performance aerated filters has been designed to treat the unscreened effluent from sites with population equivalents in the range of 5 up to 60 persons. The HIPAF is intended to serve remote rural communities, such as housing developments, hotels, camping and caravan sites, or any facility not connected to main sewers.

The process used within the HIPAF has been developed to meet the more stringent discharge consents now being imposed by the Environment Agency, particularly with reference to low ammonia levels. The HIPAF can achieve ammonia standards better than 10mg/l.

The plant is designed for in ground installation. Blowers and controls to provide the air are housed in a kiosk adjacent to the plant. All tanks, covers and kiosk are manufactured in GRP for corrosion resistance and long life.

The sewage effluent undergoes three treatment phases in three distinct sections. For a full description of the treatment process see [Appendix II](#)

- Primary settlement tank
- Submerged-bed aerated filter
- Final settlement tank

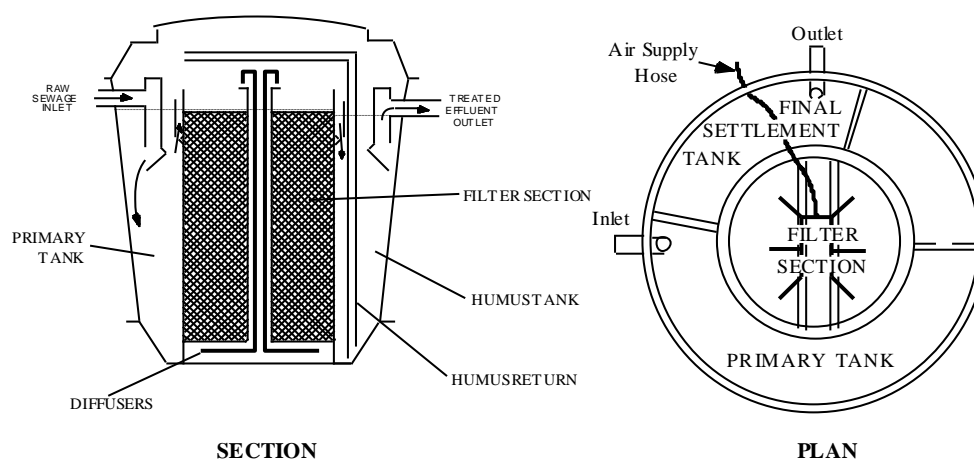

Figure 1. HiPAF general arrangement (Plan and Section)

4 PLANT OPERATION

The plant is designed to operate automatically with minimum maintenance after it has been commissioned. The plant will provide effluent within the designed discharge consent standard after an initial start-up period, up to 10 weeks depending on the water temperature and site conditions. It is important that the sewage - input conditions are kept within the plant design criteria. See [Appendix III](#) for Start-Up Procedure.

The blower is used to aerate the filter and runs continuously.

THERE ARE TWO ESSENTIAL TASKS:

- **DE-SLUDGING THE PRIMARY TANK (between 2 to 4 months)**
Note: See [Appendix I](#), for specific de-sludging amounts and periods.
- **BLOWER MAINTENANCE – Please refer to Section 7, Air Blowers.**

4.1 Primary Settlement Tank Operation

4.1.1 Operation

Raw sewage gravitates to the primary settlement tank where about 30% of the BOD (Biological Oxygen Demand) load is anticipated to settle down.

4.1.2 Emptying

Typical emptying frequencies vary depending on solids loading rates seen in the wastewater, but the primary sludge should NOT stay more than 180 days inside of the tank as it gets septic.

4.2 Bio-zone Operation

Partially treated flow gravitates to the SAF (Submerged Aerated Filter) to pass through high voidage plastic media where both carbonaceous and nitrifying processes take place. Air to oxidise the influent and to scour excess biomass from the SAF filter media is introduced continuously below each chamber by a series of diffusers. Each diffuser is capable of being removed for maintenance without the necessity to shut down the plant.

The bacteria necessary to provide the biological oxidation are present in normal sewage and will rapidly multiply if the bed is aerated. The process breaks down most of the sewage into carbon dioxide and water.

There are two main types of bacteria: -

- Carbonaceous bacteria which, as the name suggests will break down the carbon-based solids.
- Nitrifying bacteria which break down the ammonia to nitrite and nitrite is oxidized to nitrate.

The carbonaceous bacteria are more prolific and also less prone to damage by chemicals (cleaning agents) than the nitrifying bacteria. Both are adversely affected by low temperatures or low pH which may be found in soft water areas. The nitrifiers are more critical and cease to be effective in temperatures below 10 deg C or pH below 7. Low temperatures are not normally found in domestic sewage, this will rarely drop below 10 deg C unless the pipe runs are very long or the flow very small.

WCSEE Ltd plants generally produce a Phosphate concentration of 3-6 mg/l from municipal type influent. This can be further reduced using a dosing system if necessary. (Not supplied for the project).

Following biological treatment, the effluent flows into the humus settlement zone incorporated in a single GRP tank with biological stage where the excess biomass settles down. The humus settlement tank is equipped with an airlift operated sludge draw-off system which will automatically transfer accumulated sludge to the primary settlement tank.

Air required for biological treatment will be provided by **a duty only blower**. Air supplied is monitored by an alarm system that alerts operators via SMS messages or illuminate kiosk's beacon.

4.2.1 Maintenance of the Bio-zone Tank

Maintain the bio-zone tank as described below of this manual. If you are in any doubt, please contact WCSEE Ltd office.

4.3 Fan Operation and Control

The fan supplied is working when the panel is energized.

4.4 Blower Operation and Control

The Air Blower operates on a duty only configuration.

Any failures will send a signal illuminating the alarm beacon to the operator.

Process air requirement is supplied by duty only air pump arrangement. One blower of Kubicek model 3D19T-050E. It is powered and once installed, connected to the manifold using 1" high temperature hose. Blower operates either by:

4.4.1 Automatic Control

Automatic control is achieved by setting the air blower Hand/Off/Auto switch to "Auto"; these switches are located on the panel fascia. This will activate the pre-set timers within the panel activating blowers' rotation program.

4.4.2 TIMER

There is a timer positioned inside the control panel on the back side of the door. It is to reduce the power consumption by turning off and on the blower in 15min intervals, during normal operation. (Note: - the Blower should be running 24/7 for the first 6-8 weeks or until the plant is fully seeded).

Only the site operator should adjust the settings.

4.4.2.1 Timer Set Up

To set up the timer, follow the below steps:

- Selecting the "A" letter on the bottom left of the timer, means the timer is in the "Auto" position. (As indicated in Picture 1 below). This set-up will allow the timer to be in operation.
- When the main switch (located on the front of the control panel) is in the "Auto" position, the low air pressure switch will be automatically inhibited to OFF for a certain period of time when the blower stops, so the beacon will not flash showing a fault.



Picture 1

- On the Timer, Once the "Auto" mode is selected, select the cycles required for the blower ON/OFF times. This will be done by moving the switches from the circle of yellow tabs to the outwards position for ON and the inwards position for OFF (see Picture 2 below).
- The Initial set-up is for 15min OFF and 15min ON. If the quality of effluent is deteriorating, increase the blower ON time by moving more yellow tabs to the outwards position.

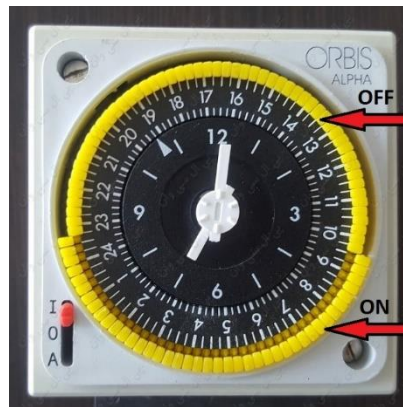

Picture 2

- On the Timer, selecting the letter "I" on the bottom left of the timer mode will run the blower in manual setting, (as indicated in Picture 3 below). It is advisable that once a week to run the blower(s) in manual mode for 4 hours, to scour the media.



Picture 3

- On the Timer, selecting the letter "O" on the bottom left of the timer, will switch the blower OFF and no air will go to the plant, (as indicated in Picture 4 below).



Picture 4

4.4.2.2 General Requirements

All timers retrofitted in existing panels must be installed by WCSEE, or the process of the sewerage treatment plant will not be guaranteed by WCSEE.

On factory fitted timers, a visit is required after 2 months in operation to check the D.O. (Dissolved Oxygen Levels) and to visually inspect the effluent.

4.4.2.3 Electrical Connections

Below shows the electrical details of the timer controls.

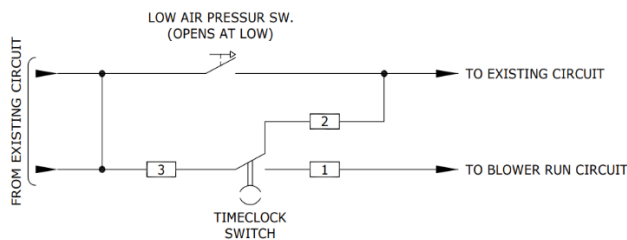
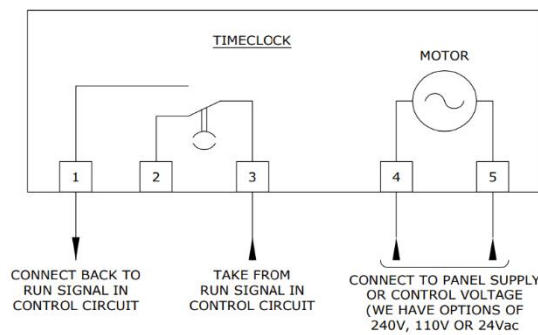

4.4.3 Manual Control

Setting the Hand/Off/Auto switch to 'Hand' will terminate the automatic control and set the blower to operate manually using 'Start' and 'Stop' buttons in the panel fascia. 'Reset' button must be pressed firstly if the blower has been repaired after a failure to resume blower operation under manual control.

5 ROUTINE MAINTENANCE

Checks:

- Weekly
- Six Monthly
- Annual

5.1 Weekly

Check that there is noise coming from the blower kiosk indicating that the blower is operational.

If a warning alarm beacon is fitted, it will flash to indicate a problem or lack of air to the plant.

5.2 Six Monthly

Carry out the weekly check plus:

- Open the Kiosks and check the blower and control panel are dry and in good working order.
- Open the Lids on the main unit and check that there is an even distribution of air around the filter indicated by an even distribution of bubbles on the surface of the filter section/s.
- Check that there is drop in the level of the liquid between the primary tank and final settlement tank.
- Check that the 'V' notches are clear of any debris.

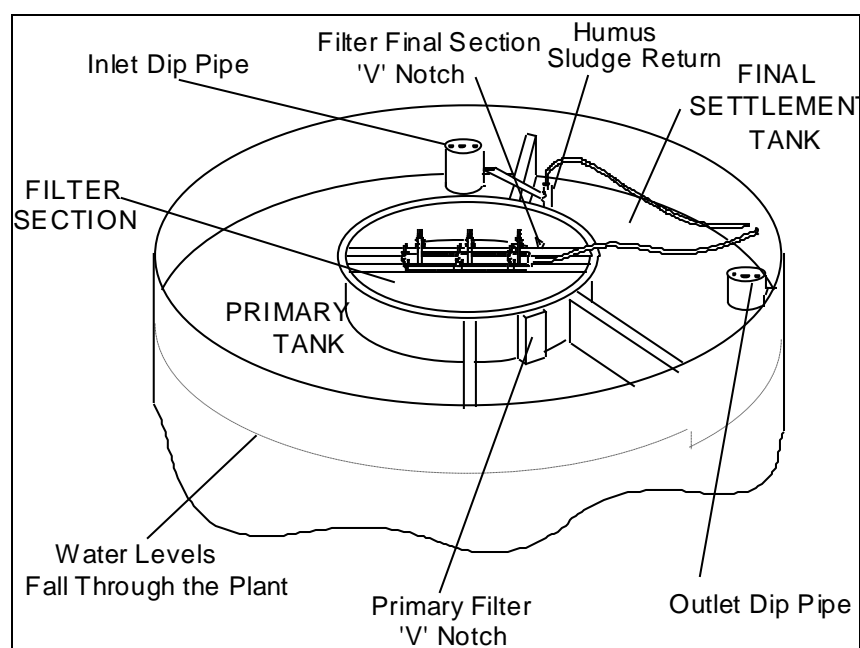

Figure 2. Detailed diagram of HiPAF

- Check that the liquid in the final settlement tank is clear and there are only a few floating solids. Any floating solids should be removed when de-sludging the primary tank (see de-sludging [Appendix I](#)).
- Check that the blower air filters are clear and knock off any collected dust or replace if necessary.
- Check air lift operation by pressing 'TEST' on the solenoid valve or test button on control panel, and see that liquor is being returned to the primary tank and is running clear by the end of the cycle. If it does not clear see problem solving [section 6](#).
- **Primary settlement tank** - check the sludge depth with probe. The top floating sludge blanket should be no more than 200mm thick and the top of the settled sludge should be at least 1m below surface, arrange de-sludge if required.
- The blower maintenance is carried out by checking the depth of the carbon vanes, see blower manual, and grease if required.

5.3 Annual

Carry out the monthly and weekly checks plus:

- Thoroughly check all the plant. If there is any scum or grease build up on the sides of the tanks or fittings this should be removed by pressure washing or removed with a wood or plastic scraper. **DO NOT USE A METAL SCRAPER.**
- Check the control panel, fan inlet filters and blower(s) for correct operation and service or replace as required.
- Check the air distribution over the filter surface, adjust position and/or clean air distribution nozzles as required. See problem solving [Section 6.3](#) and [Section 6.6](#).

6 PROBLEM SOLVING

6.1 Poor Effluent

Blower not running	Refer to 6.2
No Air bubbles in filter chamber	Refer to 6.2 & 6.3
Poor air distribution	Refer to 6.6
Plant overloaded	Refer to 7 & original design loads

6.2 Blower not running

Symptoms	Corrections
Power cut	If temporary (24/48 Hours) do nothing. If extended, obtain alternative source of power or tanker sewage away. Important: on power being returned to three phase supplies check for correct rotation of blowers
Power supply fault	Switch off blowers, check fuses and any RCD breakers. On 3-phase supplies, check for correct rotation. Switch blowers to on and the blowers should start. If not switch off and call electrician.
Blower overload has tripped	Check for any obvious causes, reset overload and switch to on. Blowers should start, if not switch off and call an electrician.
Blower runs intermittently	Check that the cooling fan is running and the air ducts are clear, as overheating in the cabinet will cause the high temperature trip to switch off the power to all but the fan and beacon if fitted. Replace fan if it has failed. Temporary solutions if the weather is fine: leave the kiosk door open but ensure that no one can gain access to electrical or rotating mechanisms.

6.3 No air bubbles showing on the surface of the filter section

Symptom	Corrections
Blower not running	Refer to 6.2
Blower running	Check all valves are open in the kiosk and main unit. Check that the airlines are not broken or leaking. Find where the air is escaping from pipe work and repair. Check inlet filter(s).

6.4 Blockages

Symptom	Correction
Level in sections is higher than normal	If the plant has been flooded due to high water level or other causes, the 'V' notches may have become blocked. These should be cleared of any debris; the material should be returned to the primary settlement tank.

6.5 Smell

Symptoms	Corrections
Smell escaping from the covers on the plant	If venting is via the inlet pipework, ensure that the outlet T-vent is closed and the inlet T-vent is open. If venting is via the outlet pipework, ensure that the inlet T-vent is closed and the outlet T-vent is open. Also check the seals around the covers and reposition as necessary.
Smell escaping from the kiosk	Check that any ducts to the plant (holding tank or pump chamber if installed) are sealed with expanding foam.
Plant smells	Check that grease has not entered the treatment plant. Do all the 'Annual Checks'.

6.6 Poor Air Distribution over the Filter Section

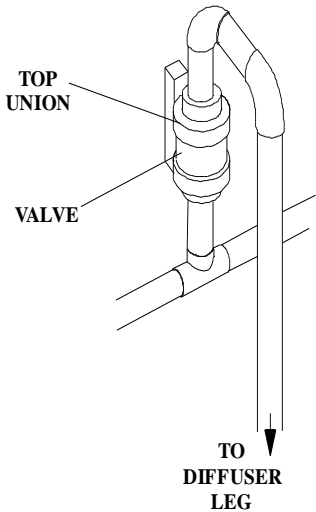
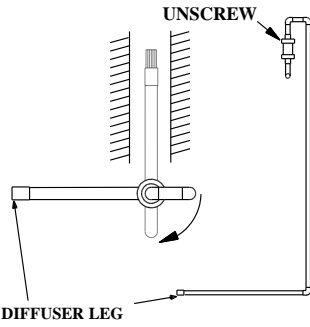
Cause	Correction
<p>Blocked air Diffusers</p> 	<p>Turn off all but one of the air diffusers at the valves. Then proceed to check the one that is on for the position of bubbles. The increased pressure should clear any blockage in the diffuser. If not, the diffuser can be removed by switching the air supply (blower) off and disconnecting the diffuser tube at the top of valve, turning through 90° and lifting up through the diffuser access slot. On early units the diffuser is screwed into the fitting on the end of the tube and can be removed for cleaning or replacement. Later units have a cap with a 5mm hole in the end. In addition, there are also some cross holes on some of the horizontal pipe. Clear all holes.</p>  <p>Repeat as required for any other suspect blocked diffusers, and then move the air diffusers by angling the tube as required to improve air distribution.</p>
<p>Filter media partially blocked by excessive biomass</p>	<p>This indicates that the plant is overloaded, check design loading and contact WCSEE Ltd for advice.</p>
<p>Filter media partially blocked with sludge</p>	<p>This indicates carry over from primary tank, check sludge levels and de-sludge if required. Also check for excessive flow possibly due to ground water ingress into foul sewer.</p>

6.7 Floating scum layer on final settlement tank

Symptom	Correction
Low humus flow return	<p>Carry out a check by instigating extra return cycles. Depress the test button on the timer (mounted on the manifold pipe work in the kiosk or on the control panel). Check that the returned liquor begins to clear by the end of a cycle. If it does not start to clear within the cycle, increase the on time by 1/2 a minute. Continue instigating extra cycles until the humus return starts to run clear. If the return rate is low from the air lift, check the depth of the air line by sliding the tube into the top of the 'T' piece in the final settlement tank, (see figure 2 on page 6) whilst the air lift is running. Air should begin to bubble up, when this happens pull the tube back 200mm and there should then be a reasonable flow.</p> <p>CAUTION: DO NOT INCREASE THE SLUDGE RETURN EXCESSIVELY AS THIS COULD CAUSE A HYDRAULIC OVERLOAD RESULTING IN POOR QUALITY EFFLUENT.</p>

7 AIR BLOWERS

Blowers are supplied to provide process air to the biozone. It is important that the air blower is operation 24/7 for the first 6-8 weeks or until the plant is operational. When your plant is delivered to site it will be accompanied by an installation manual, operation and maintenance manual and a specific O&M manual for the blower. If these have been lost, please contact WCSEE Ltd for another set.

The air blower supplied is: -

Make: Kubicek

Model number: 3D19T-050E

Note: - If the plant is receiving flow with no air for longer than 48hours, please contact WCSEE.

8 WARRANTY LIMITATIONS

The warranty period for this plant is 25 years for manufacturing defects and 2 years for the air blower. However, WCSEE Ltd shall not be liable for any labour involved for the removal or replacement of its equipment or the subsequent transportation, handling or packaging of any part or parts thereof. In no case will WCSEE Ltd be liable for loss incurred because of interruption of service or for consequential damages, labour or expense required to repair defective units, nor shall this constitute a cause for the cancellation of the contract of purchase and sale. Specifically exempt from this warranty are limited life of consumable components subject to normal wear and tear, such as air pump vanes, diaphragms and filters.

9 NON-WARRANTY SERVICES

Service charges will be incurred (including parts and labour), due to the following:

- Unauthorised alteration.
- Accidental damage, caused by plant or movement on site outside of WCSEE's control.
- Improper use.
- Abuse.
- Tampering.
- Failure to follow installation instructions or failure to follow operating and maintenance procedures.

The above will not be covered by WCSEE Ltd warranty. All service visits for non-warranty work are chargeable at the standard engineer day rate plus mobilisation. This warranty gives specific additional benefits. Statutory rights are unaffected.

WCSEE Ltd will not uphold the guarantee on the purchased equipment if the routine maintenance has not been performed and documented. WCSEE Ltd strongly recommends that the installation of the purchased product is carried out by a qualified and experienced installer. Dependent on the site a qualified civil engineer may need to be consulted for the construction of suitable base slab to support the imposed load.

APPENDIX I – De-sludging

This procedure details how the sludge should be removed from the primary tank via a tanker for disposal. All such matter must be removed because any remaining sludge may go septic and start to cause foul odours. Also, excessive accumulation of scum may result in the carry-over of solids into the biofilter section resulting in blockages in the filter media and a rapid deterioration in final effluent quality.

**DO NOT REMOVE ANY SCUM OR LIQUOR FROM THE HUMUS TANK
UNTIL THE PRIMARY TANK HAS BEEN DESLUDGED.**

NOTE: - There is a flap valve between the primary tank and the humus tank that allows flow from the final settlement tank into the primary tank during de-sludging to avoid undue sudden pressure on the baffles.

IF THE HUMUS TANK IS EMPTIED, IT **MUST BE REFILLED WITH CLEAN WATER TO
THE FLAP VALVE LEVEL **BEFORE** THE PRIMARY TANK IS FILLED.**

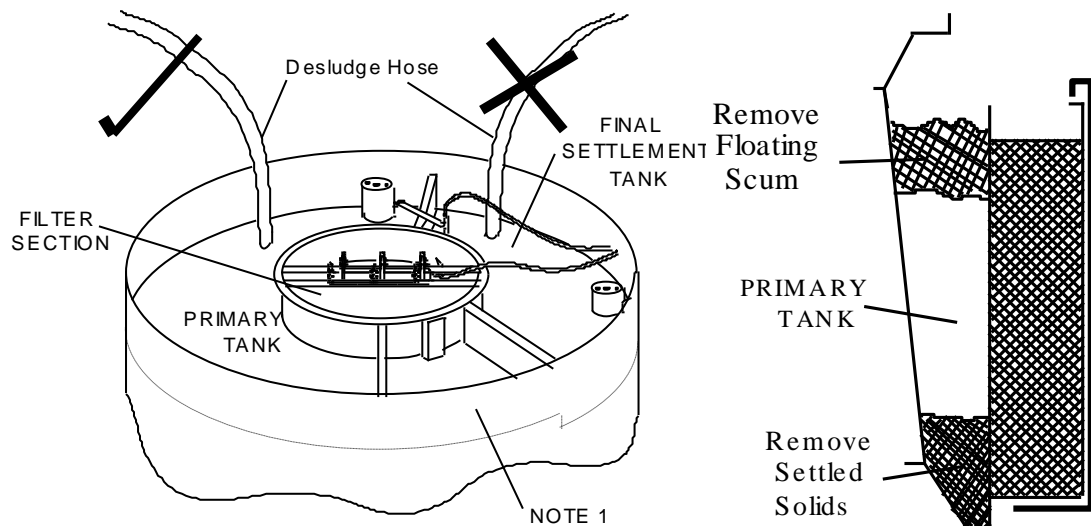

Figure 3. De-sludge removal diagram.

Remove the scum layer first, then place the hose to bottom and suck out the settled sludge. The amount should be approximately divided 2/3 and 1/3 between the front and subsequent sections. The larger quantity should be taken from the first section of the primary and the remainder from the last section.

The actual quantity of sludge taken from the primary tanks may vary from the amount quoted.

Note: A large thick scum layer (removed first), is quite normal in many cases. Please see the table below for the exact de-sludge amounts from your HPC plant.

PRIMARY SLUDGE TO BE REMOVED EVERY <u>90 DAYS</u>		
UNSETTLED BOD LOAD kg/day	3.75	
TOTAL SLUDGE TO BE REMOVED FROM SITE	6.075m ³	
PRIMARY TANK		
REPLACE WITH SITE SPECIFIC		
<small>(CLOSEST ZONE TO THE INLET)</small>		
ZONE 2 1/3	LID 1	2.03m ³
NOTES:- ANY SCUM SHOULD BE REMOVED FIRST BEFORE LOWERING THE HOSE DOWN TO REMOVE THE SLUDGE.		

It is desirable to refill the primary tank with water as soon as possible. Do not leave the primary tank lower than normal level for more than a day.

NOTE: - If the water table is very high or flood conditions have recently been present **DO NOT DESLUDGE** the primary tank. Please contact WCSEE for advice.

APPENDIX II – Plant Description

This description is only supplied for interest and is not essential reading for plant operation or maintenance. The HIPAF will be supplied as a one-piece unit, internally divided into 3 sections.

The function and operation are as follows:

- **Primary section**

This receives the flow of raw sewage directly from the foul sewer or pumping station. The design of this section reduces the upward flow velocity of the sewage to less than 0.9 m/hr at peak flows into the plant as specified in BS6297. At this low velocity any suspended matter is no longer carried and thus settles out as sludge in the bottom of the tank, to be removed by tanker as necessary. This settlement reduces the biological oxygen demand (BOD) of the clarified liquor flowing into the aerated filter section by up to 30%.

The volume of liquor in this section also service to equalise the strength of the incoming sewage before it flows into the next section. The inlet and outlet to the tank are baffled to avoid disturbing the settlement of solids. The section also has a baffle across the flow from inlet to outlet to assist in holding back any floating scum that may occur.

An airlift removes any settled solids and some aerated liquor from the final settlement section and returns to the first part of the primary section. This treated liquor helps to keep the primary tank from turning septic and producing bad odours.

- **Submerged bed aerated filter section**

WCSEE's innovated submerged-bed aerated filter houses a hybrid version of two well-established biological treatment processes. It is a combination of a fixed film reactor system and a suspended floc dispersed growth system for bacteriological oxidation, with the high transfer rates and operational control of the dispersed growth system.

The filter contains high voidage plastic media, on which a wide range of sewage digestion organisms developed. The process of biological oxidation gives off carbon dioxide and humus sludge as by-products. The supply of air is introduced at the bottom of the filter by a series of bubble diffuser nozzles.

The humus sludge produced as a result of bacteriological oxidation in the filter bed is transferred with the liquor into the final settlement section.

- **Final settlement section**

This section is designed to allow humus sludge produced in the filter section to settle out and be returned to the primary section by an airlift. The airlift is controlled by a timed valve, initially set for 3 mins every 40 mins.

To assist in collecting the sludge the end of the section is conical and the sides also slope to concentrate the sludge into a small area around the airlift pipe.

APPENDIX III - Plant Start up

For commissioning, carry out the checks as in [section 5.3](#) "Annual Checks" of this manual. The plant should then be left running as normal. It takes time, depending on the temperature, for the plant to grow a stable biomass when it is first started up. This is 3 to 6 weeks for the process to start reducing the BOD. It then takes another 4 weeks for the process to start reducing the ammonia.

Introduction

The bacteria necessary to provide the biological oxidation are present in normal sewage and will rapidly multiply if given the right conditions. The process breaks down most of the sewage into carbon dioxide and water.

There are two main types of bacteria: -

- Carbonaceous bacteria which, as the name suggests will break down the carbon-based solids.
- Nitrifying bacteria which break down the ammonia to nitrogen, and this will be partially converted to nitrogen gas before being discharged.

The carbonaceous bacteria are more prolific and also less prone to damage by chemicals (cleaning agents) than the nitrifying bacteria. Both are adversely affected by low temperatures or low pH which may be found in soft water areas. The nitrifiers are more critical and cease to be effective in temperatures below 10°C or pH below 7. Low temperatures are not normally found in domestic sewage, this will rarely drop below 15°C unless the pipe runs are very long or the flow very small.

The right conditions to grow bacteria are to have both oxygen and food available and these conditions are found in the Submerged bed aerated filter section of the HIPAF.

See [Appendix II](#).

The effluent quality is defined by a group of two or three figures as BOD:SS:NH₃ (Biological Oxygen Demand: Suspended Solids: Ammonia). All figures represent the concentration in ppm (parts per million) and the most usual requirement is 20:30 with no Ammonia standard. If the discharge point is very sensitive the standard may be as tight as 10:10:5

Start Up

It is very important that the air blowers are switched on BEFORE any sewage is allowed to flow into the Aerated filter section or the Humus section of the plant.

The plant will have been left full or partly full with water by the installers and as soon as sewage is introduced into the Primary tank to provide flow the bacterial action will commence. The carbonaceous break down will start almost immediately which will produce large quantities of foam. Although the process will have started the initial quality of the effluent will initially be poor with little treatment.

As the plant initially contained water the sewage will be diluted and usually it will be permitted to discharge effluent below the required level for a limited period. If, however no discharge below the consent level is allowed it will be necessary to re cycle sewage through the plant to build up the bacteria. This can be done by using the Humus sludge return.

In order to reduce the time to full treatment the plant can be seeded with activated sludge and / or proprietary bacteria, BUT a quantity of normal sewage will also be required.

Procedure: -

Switch on Blower and check that air distribution is correct and the sludge return air lifts are working.

Introduce sewage into the Primary tank at the normal or reduced rate.

Check after 12 to 24 hours that: -

- Blower is running correctly and not overheating
- Air distribution in the Filter section is correct and that foam is being produced
- The Humus return system is working correctly.
- Forward Feed is working and feeding forward at a rate of 1.2 to 1.5 times the design DWF (Dry Weather Flow), adjust the timer as required- preferably on every 10 minutes for a short time.

APPENDIX IV - IF DISCHARGE BELOW CONSENT LEVEL IS NOT ALLOWED

- Place bung in final outlet pipe to prevent discharge
- Switch on Blower and check that air distribution is correct and sludge return air lifts or pumps are working.
- Lower the water level to approximately 1m below the normal water level to provide space for sewage or activated sludge.
- Introduce sewage or activated sludge into the Primary tank to 150mm below the normal level. Check temperature of liquor and if below 15°C it is advisable to provide some form of heating to this temperature.
- Allow the plant to run for a few hours, keeping a watch on the liquor level in the Humus tank. If this starts to rise adjust the timer(s) on the Sludge return system until stable.
- Continue to fill the Primary Tank with sewage to near the normal level and then stop OR provide other storage for liquor pumped from the Humus tank.
- Allow system to recirculate for a few days, adding small volumes of fresh sewage or activated sludge to the primary tank to maintain feed to the filter section.
- If required to speed up the treatment process now is the most effective time to introduce proprietary bacteria, as per the manufacturer's instructions.
- Tests on samples taken from the Humus tank are worth starting after 7 to 10 days, but because of the high rate of recirculation the solids content may be high and adversely affect the results of both BOD and SS. If there is an ammonia standard, once this has been reached it is very likely that the BOD and SS will also be within the limits required.
- Once the samples give the required quality the bung(s) can be removed and sewage allowed to flow. This flow should be at a reduced rate initially and gradually introduced over a few days before the full load is reached.

Standard Settings for Timer Valves on Forward Feed and Sludge Return

Forward Feed	2 minutes on, 8 minutes off
Sludge Return	3 minutes on, 45 minutes off

APPENDIX V – Seeding with Activated Sludge

Seeding HiPAF plants to accelerate the time for the plant to mature and meet the design effluent consent

In order to reduce the time required for full treatment to take place, the process can be seeded with activated sludge and / or proprietary bacteria. The steps below should be followed so as to ensure the process is not subjected to any overloading or other misuse that could compromise its performance.

1. Prior to the addition of any activated sludge or seed, the sections of the unit require filling to top water level with water.
2. The system should be switched to "Auto" on the control panel to begin process operations, starting the air compressor and associated air lift pumps.
3. The timings on the forward feed and humus returns should be adjusted during this seeding in period, which may last for one week so as to recirculate at a high rate, thus processing more sewage and bacterial seed through the biozone. This is especially true in situations where a discharge is only permitted by the EA if it meets consent. Recommended timings are 5 minutes on, 5 minutes off for both solenoid valves. These must be returned to factory default settings immediately following completion of the seeding in phase.
4. Activated sludge should then be introduced to the primary tank with an equal or greater volume of crude sewage. **IMPORTANT:** Under **no** circumstance should sludge be introduced into the biozone directly.
5. The forward feed pumps located in the primary tank will now begin the process of transferring bacterial seed / activated sludge across to the biozone at diluted concentrations to seed the media.
6. If discharge above the consented levels is permitted for any dispensation period, crude sewage flows should be allowed to enter the HiPAF in the normal fashion.
7. The process should be fully monitored during this seeding in phase with effluent samples taken and analysed for BOD, COD, TSS, Ammoniacal Nitrogen and ph. Under normal circumstance full BOD treatment occurs between 6 – 8 weeks with nitrification being achieved between 12 – 16 weeks. Seeding a HiPAF can reduce the time required for the process to achieve consent compliance.
8. Results will vary dependent upon ambient conditions such as water temperature, crude sewage strength, activated sludge mixed liquor concentrations and biomass health.

Industrial wastewater treatment

+44 (0) 15 3083 0020

Sewage treatment

+44 (0) 23 9224 2600

info@wcs-group.co.uk

wcs-group.co.uk/environmental-engineering

Disclaimer

WCS Environmental Engineering (WCSEE) has a policy of continual product development and the above information may be subject to change without notice. WCSEE reserve the right to to change the specification in line with company policy of improvement through research and development. Errors and omissions excepted. Models shown in this manual may include additional cost options that are not part of the standard specification