

The logo for WCS Environmental Engineering features a teal swoosh above the text. The text 'WCS' is in a large, bold, dark blue font, followed by 'Environmental Engineering' in a smaller, dark blue font.

WCS Environmental
Engineering

A WCS Group Company

HPC (HIPAF COMPACT)

INSTALLATION MANUAL

TABLE OF CONTENTS

1	HEALTH AND SAFETY	4
1.1	Health	4
	Leptospirosis	4
1.2	Sensible Precautions.....	5
1.3	Vaccinations	5
1.4	Safety.....	5
2	RISK ASSESSMENT NOTES.....	5
3	INTRODUCTION.....	7
4	DELIVERY.....	9
4.1	Off Loading.....	9
4.2	Extent of Supply	9
4.3	Electrical Equipment.....	9
4.4	Bolts and Bolt Strips	9
4.5	LIFTING.....	10
5	TANK INSTALLATION.....	11
5.1	INSTALLATION OF UNIT.....	11
5.2	LOCAL GROUND CONDITIONS	13
6	INSTALLATION OF KIOSKS	13
6.1	CONNECTIONS TO KIOSKS.....	14
7	PIPE WORK, DUCTS AND SAMPLE CHAMBERS.....	14
7.1	Pipe Work.....	14
7.2	Ducts and Hose Draw Chambers	14
7.3	Sample chamber.....	15
8	ELECTRICAL INSTALLATION.....	16
8.1	Three Phase connection	16
9	COMMISSIONING.....	16
10	KIOSKS AND BASE SLABS.....	17
	Blower Kiosk.....	17
	Control Panel Kiosk.....	17

Revision History:

Date	Change description	Owner	Checked	Revision
03/02/2023	2023 ISSUE	TC	BD	A

1 HEALTH AND SAFETY

United Kingdom Health and Safety at Work Act 1974

Section 6a of this act requires manufacturers to advise their customers on the safety and the handling precautions to be observed when operating, maintaining and servicing their products.

The user's attention is drawn to the following:

- All the sections of this manual must be read before working on the equipment.
- Suitably trained and qualified personnel must carry out installation.
- Normal safety precautions must be taken and appropriate procedures observed to avoid accidents.

The design factors for the lid loads and materials comply with the British Water Code of Practice, BW:COP.22.96. The lids have been tested with a load at 1.0Kn/m² and will withstand accidental passage.

THEY ARE NOT DESIGNED AS PEDESTRIAN WALKWAYS.

Refer to WCSEE Ltd for any further technical advice or product information.

1.1 Health

The following is extracted from a health-warning card supplied to all WCSEE Ltd staff. It is the client's responsibility to ensure that all necessary protective clothing/equipment is available.

Leptospirosis

There are two types of Leptospirosis that can affect people in the UK:

- **Weil's disease.**
This is a serious infection transmitted to humans by contact with soil, water or sewage that has been contaminated with urine from infected rats.
- **Hardjo-type Leptospirosis**
This is transmitted from cattle to humans.

Typical symptoms

Both diseases start with flu-like illness with a persistent and severe headache, muscle pains and vomiting. Jaundice appears about the fourth day of illness.

How is it caught?

The bacteria can enter your body through cuts and scratches and through the lining of the mouth, throat and eyes.

1.2 Sensible Precautions

After having worked in sewage or with anything contaminated with sewage, wash your hands and forearms thoroughly with soap and water. If your clothing or boots are contaminated with sewage, wash thoroughly after handling them.

Take immediate action to wash thoroughly with clean water any cut, scratch or abrasion of the skin immediately prior to applying any protective covering.

**DO NOT HANDLE FOOD, DRINK OR SMOKING MATERIAL
WITHOUT FIRST WASHING YOUR HANDS.**

**IF, AFTER COMING INTO CONTACT WITH SEWAGE YOU CONTRACT THE SYMPTOMS
DESCRIBED, REPORT TO YOUR DOCTOR IMMEDIATELY AND ADVISE HIM/HER OF THE
CIRCUMSTANCES.**

1.3 Vaccinations

To avoid illness, it is recommended that site personnel have the following vaccinations. (Your doctor may recommend further).

Hepatitis A

Hepatitis B

Polio

Tetanus

Typhoid/Cholera (probably carried out as a child).

1.4 Safety

Sewage gases are potentially explosive and toxic. **DO NOT** enter any of the below ground compartments of the **HIPAF UNLESS PROPERLY QUALIFIED AND EQUIPPED TO DO SO.**

2 RISK ASSESSMENT NOTES

This section of the manual is intended as a guide and as such does not cater for every situation that may be experienced on site. WCSEE Ltd assumes that the installer/end user has ensured that all necessary permissions have been sought and granted and that the installation procedures will be carried out observing the requirements of the Health & Safety regulations and will involve good building and sound civil engineering practice. Please ensure that due consideration has been given to and appropriate action taken with regard to the following:

- Planning permissions & Building Regulations and other regulating or interested parties.
- Environment Agency consent to discharge.
- The legal responsibility for the plant as far as operation and maintenance and ongoing discharge is concerned.
- Failure to comply with any regulation may result in pollution, odour and nuisance and health hazards, which may lead to legal action.
- The size of the plant relevant to the number and type of people that will be using it, e.g. domestic, light industrial, etc. consideration should be given to any unusual conditions such as B & B accommodation, special laundry requirements and frequent entertaining.
- Costs, legal implications and siting in consideration to shared systems.
- The whereabouts of wells, boreholes and springs used as sources of potable water; existing non-mains sewerage systems and soakaways; water courses, ponds and lakes and designated protected areas.
- The whereabouts of other services, pipes, cables, ducts, etc.
- Local ground conditions. Is specialist knowledge of civil engineering required to cater for unusual soil conditions such as underground rivers, running sand, chemicals in the soil, etc?
- The water table at the time of installation. Specialist knowledge is required when installing in an excavation that allows water to enter.
- The water table in winter. Special consideration should be given to installations that will be subject to high water table pressure or flood conditions. The treatment plant will need to be installed so that it cannot “float” out of the ground and provision made for continued discharge of treated effluent, should the discharge pipework/soakaway be under water.
- Failure to maintain the ability to discharge may result in pollution, odour and nuisance and health hazards, which may lead to legal action. WCSEE cannot be held responsible for failure to discharge due to poorly designed, constructed or positioned soakaways and discharge pipework systems.
- The plant must be sited within 30m of heavy vehicle access for de-sludging. The plant should, where possible, be sited above the high water table mark and above or beyond the flood plain.
- The plant should be sited as far from the habitable parts of the dwelling as possible. Many local authorities recommend 10m as a minimum, but easements are possible for smaller sites.
- WCSEE recommend that the plant be vented. This can be via the vent pipe, normally attached to the building, or by additional venting (high or low level) off of the inlet or outlet pipework or the sample chamber.
- A safe and adequate sampling point is usually a requirement of the Environment Agency. This can be an off the shelf item or constructed using standard drainage components. Open pipe discharges to ditches, watercourses, etc, through pipework of less than 5m in length, do not require a sampling point if the effluent can be sampled from the end of the pipe.
- A qualified electrician (see Electrical Installation section) should only undertake electrical installation. A safe and reliable power supply is required at all times, as the air blower is required to run continuously. Adequate means of air or power failure

indication should be provided. This can be an audible or visual alarm or by regular manual checks.

- Due to the health risks associated with raw sewage, WCSEE recommend that the sewage treatment plant is not used until the system is complete, commissioned and handed over.
- Before carrying out any maintenance or installation work, the equipment must be electrically isolated. Do not leave covers open for any longer than necessary. Temporary barriers and warning signs should be erected around any open covers or manholes as appropriate, in particular warning of deep water in the tanks.
- Any visiting personnel must report to site office or householder on arrival and fully acquaint themselves with safety regulations applicable.

3 INTRODUCTION

The HIPAF circular range of high performance aerated filters has been designed to treat the unscreened effluent from sites with population equivalents in the range of 1 up to 60 persons. The HIPAF is intended to serve remote rural communities, such as housing developments, hotels, camping and caravan sites, or any facility not connected to main sewers.

The process used within the HIPAF has been developed to meet the more stringent discharge consents now being imposed by the Environment Agency, particularly with reference to low ammonia levels. The HIPAF can be designed to achieve ammonia standards better than 5mg/L.

The plant is designed for below ground installation and constructed in GRP (Glass Reinforced Plastic). The sewage effluent undergoes three process phases in three distinct sections:

- Primary settlement tank
- Submerged-bed aerated filter
- Final settlement tank

The Primary tank has a baffle to prevent the carryover of solids to the filter compartment, and for the larger plants there is a separate tank module.

In the filter section, the biological treatment of the settled sewage takes place by the process of bacteriological oxidation. The filter tank contains high voidage plastic media on which the oxidising bacteria develop, in the form of a jelly like substance known as 'Biomass'. The media is supported between two perforated plastic plates that allow the passage of air and effluent, but prevents any loss of media.

Located below the lower grid is a set of air diffusers. These diffusers distribute the air across the filter, and can be removed for servicing without emptying the unit or removing filter media.

A GRP Kiosk to house the air blower(s) and a control panel are provided and should be located close to the plant. Plastic hose is used to connect the air blower to the air diffusers and humus sludge return air lift. 10m lengths of flexible hoses are provided for this purpose.

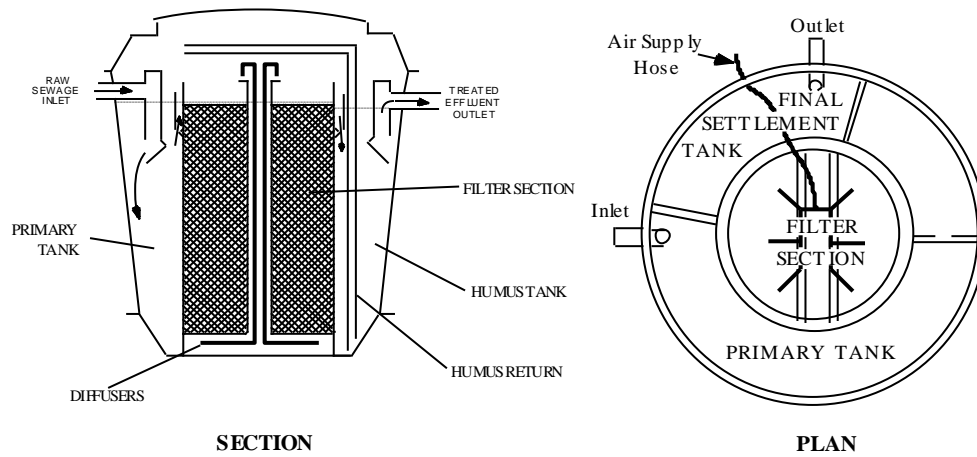

Figure 1. HiPAF general arrangement (Plan and Section)

4 DELIVERY

4.1 Off Loading

The purchaser may be responsible for off-loading at the nearest roadway to site that is suitable for heavy goods vehicles. A minimum height clearance of 16' 6" is required. If there are electrical cables overhead ensure there is a means of turning the power off. For off-loading from a lorry mounted HIAB there needs to be a firm area for the stabilisers, with the total width being a minimum of 15 feet.

If the nearest road access for a heavy goods vehicle is not adjacent to the site, it is the responsibility of the purchaser to arrange transport from the road to the site. If in doubt contact WCSEE as soon as possible with any queries.

Inspect the unit for any damage to the base before placing on the ground and then inspect the sides. The unit should only be placed on level ground with no sharp stones, bricks etc. as they may damage the base of the unit.

The control panel and blowers should be stored in suitable conditions i.e. condensation free.

4.2 Extent of Supply

See the delivery note for full details. The standard unit comes with the following:

- GRP tank incorporating the three sections.
- Blower kiosk, panel and manifold steel kiosk.
- Air hoses of 10m length.

4.3 Electrical Equipment

All electrical equipment, including the blower, must be stored in clean dry conditions until required for use.

4.4 Bolts and Bolt Strips

Due to the settling of the joints during transportation, the bolts may become loose and need tightening. It is important that the bolt strips are not over tightened as this can cause leaks.

Tighten all bolts in the metal strips to 50 NM to ensure the foam is all compressed then tighten up to a final value of 60 NM.

Silo Bolts (with no metal strips) around the top of the unit should only be tightened to 30 NM.

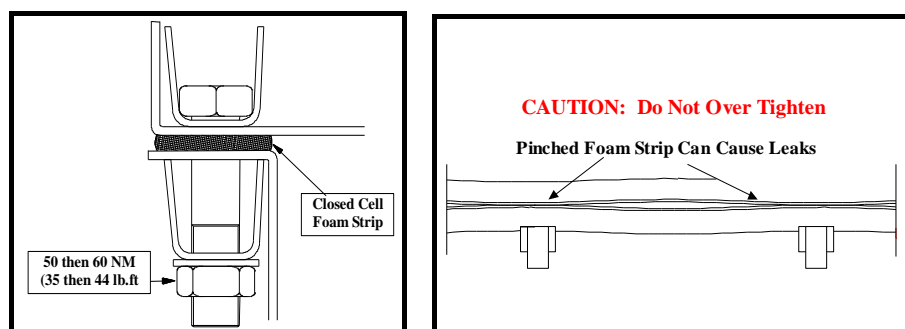

Figure 2. Bolt and Bolt Strip tightening specifications

4.5 LIFTING

DO NOT attempt to lift the unit if it contains water in any of the watertight sections. These sections are the primary, submerged aerated filter and humus settlement (see diagram in introduction page 5), and sand filter when applicable.

DO NOT walk on top of the units with muddy boots as this will scratch the surface.

Note: Units with extension turrets with covers, for inverts greater than 0.5m, are supplied separately and therefore the unit may collect rainwater.

Lifting eyes are provided around the top flange of the unit for the attachment of suitable strops of equal length. These should create an angle of no less than 60° to the top of the unit to avoid excessive loads on the sides of the structure. When moving across rough ground great care should be taken to avoid increased loads due to sudden movement of the unit.

WARNING: Care should be taken when attaching lifting equipment as the surface of the unit becomes very slippery when wet.

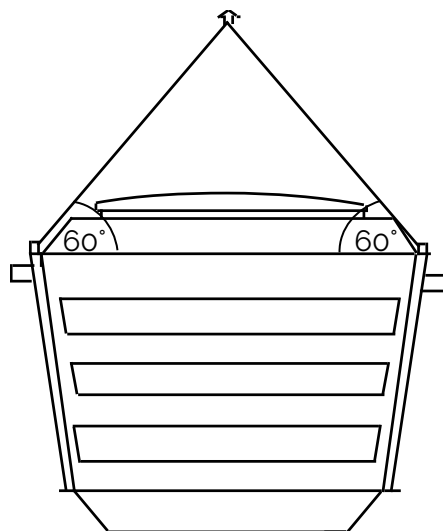

Figure 3. Correct lifting procedure

5 TANK INSTALLATION

All installation procedures should be carried out observing the requirements of the Health and Safety at Work Act and involve good building practice.

Calculate the amount of backfill required. THIS IS VERY IMPORTANT. See Section 5.1, Step 7. A qualified civil engineer must be consulted to determine the correct grade of concrete. Lean mix or dry mix concrete must be used to backfill the excavation. However, prevailing local ground condition may override this requirement. If wet mix concrete is to be used, further consultations with a civil engineer may be required. Note: the pour cannot take place in a single operation. Contact WCSEE for further information.

During the course of installation the following will be required:

- Normal construction equipment and plant.
- Concrete for base. This MUST be designed to support the unit for normal operation.
- Adequate supply of water to fill unit.
- Pumping equipment where necessary.

N.B. Installing in an excavation that allows water to enter (i.e. is not dry) requires special advice. Water table and flood conditions are typical examples that will cause problems during installation. It may also affect the operation of the plant. Again, specialist advice must be taken in these conditions.

Venting - All sewage treatment processes produce waste gasses and this can give rise to unpleasant odours. To avoid problems it is important that a high level vent is available close to the plant for venting. This vent may be from the inlet or outlet of the plant, but the inlet is preferred.

5.1 INSTALLATION OF UNIT.

Step 1- Excavate to tank dimensions (see GA Drawings) with minimum of 150mm clearance all round and under base of unit. Allow adequate clearance for all pipes and any other connectors to the unit.

Note: Dimensions are detailed on the GA Drawing for each individual plant which is sent to the customer with confirmation of order. If this has been lost, please contact WCSEE for another copy.

Step 2 - Cast the concrete base; ensure that the slab is designed to support the unit in its normal operation (i.e. full of water). The base must be level and to the correct height to suit the invert level of HIPAF inlet. Allow for initial set before positioning the unit.

Step 3 - Excavation must be kept dry during the installation and until the concrete has cured.

Step 4 - Ensure the surface of the concrete base is free of water, stones, etc, and lower the unit into correct position to suit pipe connections. Check the levels.

Step 5 – Stabilise the unit in excavation, taking care not to cause distortion of the unit. Fit temporary covers over all pipe connections.

Step 6 - Commence filling unit with water into all sections to a level of 500mm.

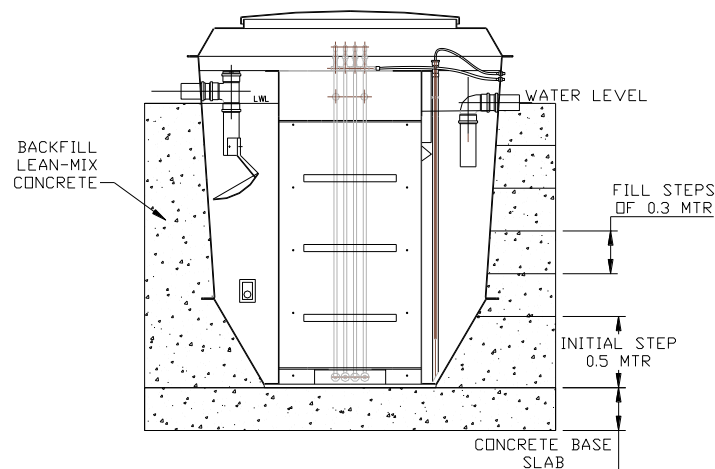

Figure 4. Concrete filling increments

Step 7 - Commence back filling with suitable lean concrete mix. The back fill must be evenly placed around the unit at all times and worked by hand up to a maximum level of 400mm above the base.

NOTE: The base of the humus tank is approximately 455mm higher than the preceding tank section(s). WCSEE advise that concrete blocks and appropriate shims are placed on the slab to support this section during back filling.

DO NOT USE VIBRATING POKERS

The water level in all sections must be increased and be kept at a level of 300mm above the top of the backfill, until final pour after step 8.

Step 8 - When the backfill is approximately 500mm below the lowest underground connections, pipe connections should be made. Remove lifting eye nuts and bolts and replace with green silo bolts supplied. Also provide for hose draw chamber, servicing ducts for the air lines and future cable connections to the unit via bulkhead connectors. If not factory fitted, fit bulkhead connections through tank top or extensions with the orientation to suit the site.

Step 9 - Continue to fill with water and backfill to the rim of the tank.

See Appendix II for directions where the invert depth is greater than 500mm.

Step 10 - Leave unit full of water.

N.B. See Appendix 1 for Kiosk Slab Dimensions and type of kiosk supplied.

5.2 LOCAL GROUND CONDITIONS

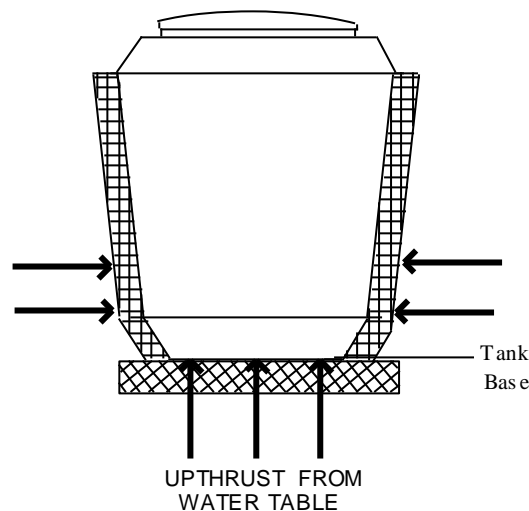

Figure 5. Pressure on HiPAF tank

The local ground conditions must be taken into account when installing the unit. The amount of concrete backfill used must be sufficient to overcome the effects from up thrust of ground water.

The unit is designed for a maximum water table of 1.0m from the base of the tank unless specified otherwise. If the water table is higher than this maximum, damage may occur when the primary tank is desludged or when other chambers are drained. The concrete backfill must be designed to stop the water table pressure damaging the tank. A qualified engineer must be consulted to determine the civil design.

N.B. Failure to do this may result in damage to the tank.

Maximum water table above base = 1.0 m

6 INSTALLATION OF KIOSKS

Step 1 - Lay a concrete slab, sized to suit the kiosk ([see Appendix I](#)), above the adjacent surface water level (and the flood plain) to avoid surface water ingress. Provision for servicing ducts for air lines, cables and mains power should be made.

Step 2 - Lay the ducting from both kiosks and then from the control panel kiosk to the unit, mains supply and any pumping chambers.

Step 3 - When the concrete slab has fully cured, secure kiosks to the slab and seal to the concrete with mastic.

6.1 CONNECTIONS TO KIOSKS

Step 1 - The air hoses and all bulkhead connections will have been delivered and placed on top of the filter section within the unit. Identify the location on the circumference of the unit above the water line, drill to suit the bulkhead connections and fit the bulkheads. Feed the hoses down the duct and connect to the bulkhead connectors now in the side of the unit using the hosedails provided. Jubilee clips are either secured to a blower or in the delivery envelope. Cut the air lines to length to allow connection to the blower manifold in the kiosk, ensuring that there are no kinks or sharp bends in the lines. It should be noted that the pipe becomes warm during operation, softens and may deform at sharp bends.

Step 2 – The Blower kiosk is separate from the manifold and panel kiosk, so additional hoses and ducts should be installed so that the hose from the blower to the manifold inlet is underground.

Step 3 - Electrical Connections ([See Section 8](#))

7 PIPE WORK, DUCTS AND SAMPLE CHAMBERS

7.1 Pipe Work

Gradient - It must be ensured that there is a sufficient fall (gradient) from the dwelling to the invert level of the inlet pipe, normally 0.5m below top lip of the unit. A fall between 1:40 and 1:100 is usually required to give a self-scouring velocity that prevents blockages in the pipes.

Venting - The plant must be vented via the inlet or outlet; a rotary disk with two holes is fitted to the top of both the inlet and outlet dip pipe assembly. Re-position the disk as required, leaving open the connection that is to provide the vent.

7.2 Ducts and Hose Draw Chambers

Ducts are required for all hose and electrical cable connections between the kiosk and the various sections of the unit. Ducts may also be required between units that are built in more than one section. At the unit end of the ducts a 'Hose Draw Chamber' is required to enable the connections to be made to the unit. The Hose Draw Chamber should be at least 300mm square and of a suitable depth to suit the connections. Ducts to the kiosk should run uphill if possible to avoid flooding the kiosk with surface water. The kiosk base should be above the surrounding ground level to avoid flooding.

7.3 Sample chamber

Positioning – This should be close to the outlet from the plant to provide a point at which the EA can take a sample.

Dimensions – The sample chamber should incorporate a large enough drop to allow a sample container to be filled with the treated discharge. The drawing below gives an indication as to dimensions.

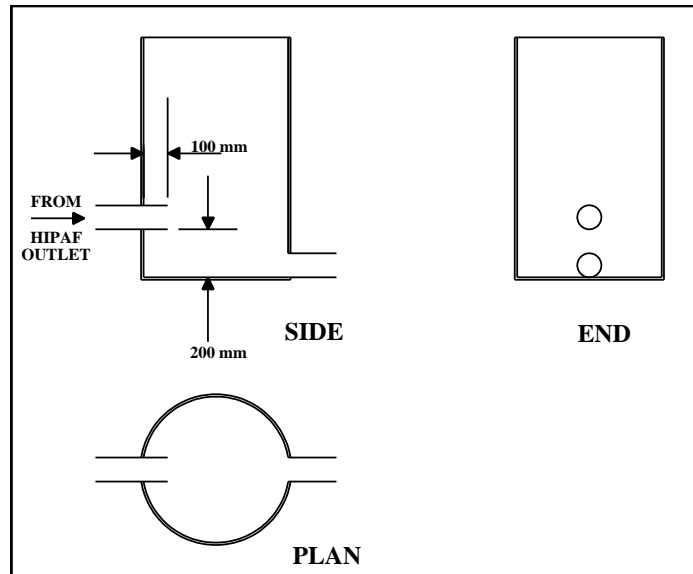

Figure 6. Sample Chamber Dimensions

8 ELECTRICAL INSTALLATION

Due to the variance of the sites and installation configurations it is not feasible to state a specific installation configuration to suit all sites. Therefore, it is important that the electrical installation is performed by a qualified electrician in accordance with the 16th or later edition of the I.E.E. regulations, with appropriate current protection devices for the site configuration.

The supply to the HIPAF should have a dedicated circuit incorporating isolation and protection devices to the regulation requirements of the Institute of Electrical Engineers. An earth leakage circuit breaker is recommended and should be incorporated into the supply to the HIPAF unit (a device with a 30mA maximum trip current is recommended).

N.B. The wiring diagram is in the electrical control panel inside the kiosk. If it is missing or lost please contact WCSEE for another copy.

8.1 Three Phase connection

When the 3-phase supply is switched on ensure the rotation of the blowers is correct, as incorrect rotation will cause damage if run for more than a brief check. This check must be done with the all airlines disconnected from the blowers.

IMPORTANT NOTE: IF THE THREE PHASE IS NOT CORRECTLY CONNECTED SERIOUS DAMAGE CAN OCCUR. SHOULD A POWER FAILURE OCCUR ISOLATE THE SUPPLY TO THE UNIT. WHEN POWER IS RECONNECTED ENSURE THE PHASES AND ROTATION ARE CORRECT.

9 COMMISSIONING

For commissioning, carry out the checks as in section 4.03 "Annual Checks" of the Operation and Maintenance Manual. The plant should then be left running as normal. It takes time, depending on the temperature, for the plant to grow a stable biomass when it is first started up. This is 3 to 6 weeks for the process to start reducing the BOD. It then takes another 4 weeks for the process to start reducing the ammonia. This process is dependent on a number of factors, including temperature. Start-up time may be longer in winter periods.

Once the plant is fully established, then and only then can the timer for the air blower be switched on. (See section 4.4.2 of the HPC operation and maintenance manual).

APPENDIX 1

10 KIOSKS AND BASE SLABS

WCSEE supplies a wide variety of blower types depending on the size of plant and site requirements. It is not possible therefore to demonstrate in a general manual the layout for the ducting exit for each kiosk. However, WCSEE will provide drawings on request showing the layout of the client's bespoke kiosk.

For each blower kiosk and control panel kiosk, there are two concrete slab sizes which are listed below. Each case the slab should be cast deep enough to take the weight of the blower(s) designated. Please refer to WCSEE before laying the concrete.

Blower Kiosk

The Blower kiosk and slab should be positioned so that you have 800mm access all around the blower for maintenance.

The concrete slab should be 750mm x 600mm.

Control Panel Kiosk

The concrete slab should be 750mm x 500mm.

Note:

Ensure that there is unobstructed air flow from all the vents otherwise overheating will occur.

Ensure the kiosk is installed above any areas likely to flood.

Industrial wastewater treatment

+44 (0) 15 3083 0020

Sewage treatment

+44 (0) 23 9224 2600

info@wcs-group.co.uk

wcs-group.co.uk/environmental-engineering

Disclaimer

WCS Environmental Engineering (WCSEE) has a policy of continual product development and the above information may be subject to change without notice. WCSEE reserve the right to to change the specification in line with company policy of improvement through research and development. Errors and omissions excepted. Models shown in this manual may include additional cost options that are not part of the standard specification